

springer newsletter

Electrical Engineering Newsletter #1/91

New and Recent Books Spanning the
Scope of Theory and Applications

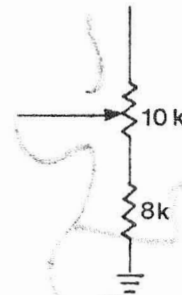
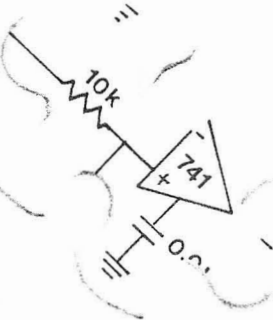
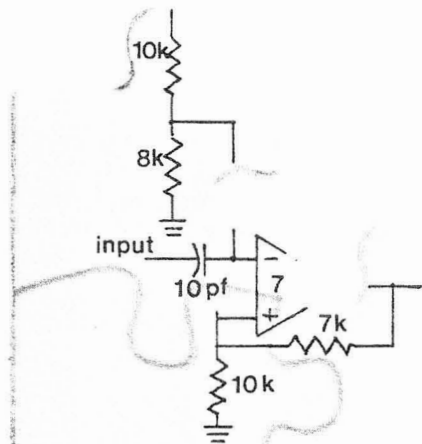
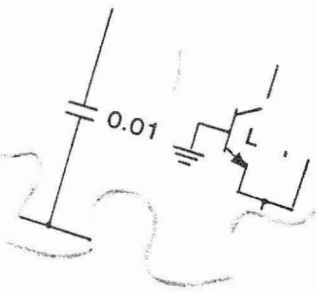
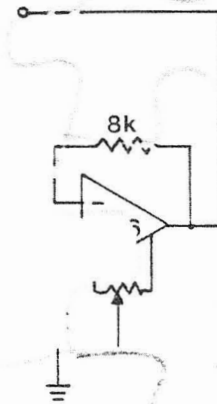
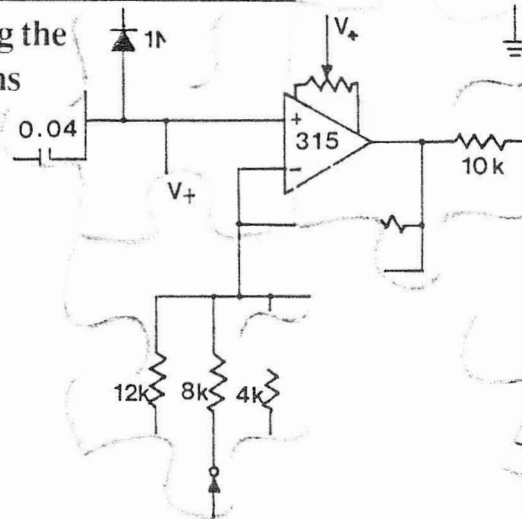
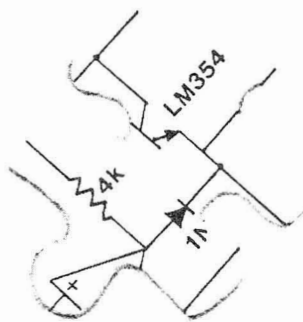

Springer-Verlag

New York Berlin Heidelberg Vienna
London Paris Tokyo Hong Kong Barcelona

New from Springer Texts in Electrical Engineering
R.J. Marks II, University of Washington, Seattle, WA
Introduction to
Shannon Sampling and
Interpolation Theory

This text is the first in signal analysis solely devoted to the topic of sampling and subsequent restoration of continuous time signals and images. The fundamentals of the sampling theorem are developed in detail. Numerous generalizations of them are treated in depth, including those of Papoulis and Kramer. Effects of truncation, data noise and jitter on restoration error are analyzed. The sampling theorem is generalized to higher dimensions, resulting in optimal sampling strategies for certain classes of images. Continuous sampling is also developed in depth. Here, a signal is restored from knowledge of its structure in one or more disjoint temporal intervals. The book contains numerous exercises with corresponding selected solutions to allow for effective self-study.

1991/324 pp., 109 illus./Hardcover/\$59.00
ISBN 0-387-97391-5
Springer Texts in Electrical Engineering

P.K. Das, Rensselaer Polytechnic Institute, Troy, NY
Optical Signal Processing:
Fundamentals

This new textbook will guide the first year graduate student from fundamentals to devices to applications in complex systems. The first half of the book covers background material in optics, signal processing, matrix algebra, ultrasound and SAW, and CCD's. The second half deals with devices and applications. Acousto-optic and electro-optic devices are emphasized, although other devices, such as the liquid crystal valve, are discussed. Applications covered include communication, spectrum analysis, adaptive filtering and image processing, to name a few. In Optical Signal Processing, the instructor will finally find a comprehensive text, ranging from basics to "hot" state-of-the-art topics, and with all necessary mathematics covered in appendices.

Contents: Introduction. Optics Fundamentals. Signal Processing Fundamentals. Introduction to SAW and CCD Technology. Optical Devices for Signal Processing. Optical Signal Processing. Special Topics of Interest. Appendices: Matrices. Orthogonal Functions and Polynomials. Principle of Stationary Phase. Vectors. Symmetry Properties of Different Coefficients in Crystal Classes.

1991/approx. 520 pp., 278 illus./Hardcover
\$69.00 (tent.)/ISBN 0-387-51476-7

See pg. 16 for Das, Lasers and Optical Engineering.

R. Tolimieri, M. An, and C. Lu, all, City University of New York, NY
Algorithms for Discrete Fourier Transform
and Convolution

This textbook provides a broad overview of the latest developments in the field of fast digital signal processing algorithms. It is intended to serve as a textbook for graduate-level courses and also a useful reference for professionals to the available DSP algorithms. The book bridges the gap between DSP algorithms and their implementation on a variety of serial and supercomputers. It shows that the mathematical concept of tensor product can be matched to machine implementation and that the tensor product formulation provides computer implementation options. It also presents modifications of Winograd FFT algorithms with a diversity of arithmetic choices. The method of presenting DSP algorithms by their algebraic structures is a strength of this book and makes the results readily accessible.

1989/350 pp./Hardcover/\$59.00/ISBN 0-387-97118-1

J.M. Mendel, University of Southern California, Los Angeles, CA
Maximum-Likelihood Deconvolution
A Journey into Model-Based Signal Processing

Explains MLD in a straightforward manner in terms of a convolutional signal generating model and ideas from optimization theory. The book focuses on the specification of a probability model for the system's measured output, determination of an appropriate likelihood function, and maximization of that function. Many practical algorithms are obtained, computational aspects are described in detail, and extensive simulations with real data are provided.

Contents: Introduction. Convolutional Model. Likelihood. Properties and Performance. Examples. Mathematical Details. Computational Considerations. References. Bibliography. Index.

1990/227 pp, 126 illus./Hardcover/\$45.00/ISBN 0-387-97208-0

Springer for Signal Processing

D.L. Snyder and M.I. Miller, both, *Washington University, St. Louis, MO*
Random Point Processes in Time and Space

Second Edition

The new edition of this senior/graduate-level textbook emphasizes point processes on multidimensional spaces, especially two dimensional, a technique of growing importance for the description of data from which images are formed. Having developed new models in their work on biomedical imaging, the authors treat constrained estimation techniques in detail, adding a chapter on translated Poisson processes. Their methods for quantitative image-formation are applicable over a wide range of scientific and engineering disciplines.

1991/approx. 492 pp., 76 illus./Hardcover/\$59.50 (tent.)
ISBN 0-387-97577-2 *Springer Texts in Electrical Engineering*

R.J. Marks II, *University of Washington, Seattle, WA*

**Introduction to Shannon Sampling
and Interpolation Theory**

This text is the first in signal analysis solely devoted to the topic of sampling and subsequent restoration of continuous time signals and images. It develops an understanding for, generalization of, and extensions for the cardinal series of Shannon sampling theory. Effects of truncation, data noise and jitter on restoration error are analyzed. Continuous sampling is also developed in depth. The book contains numerous exercises with corresponding selected solutions to allow for effective self-study.

1990/324 pp., 109 illus./Hardcover/\$59.00
ISBN 0-387-97391-5 *Springer Texts in Electrical Engineering*

S. Ranka, *Syracuse University, Syracuse, NY*, and S. Sahni, *University of Minnesota, Minneapolis, MN*

Hypercube Algorithms with Applications

This textbook/monograph develops fundamental algorithms for SIMD and MIMD hypercubes, useful for a wide variety of data manipulation tasks. The fundamental algorithms are then used to obtain efficient hypercube algorithms for matrix multiplication, image processing problems such as convolution, template matching, hough transform, and other tasks. Experimental results on an NCUBE/77 MIMD hypercube are also presented, and numerous problems and exercises are included.

1990/237 pp./Hardcover/\$39.00/ISBN 0-387-97322-2
Bilkent University Lecture Series

J.M. Mendel, *University of Southern California, Los Angeles, CA*

Maximum-Likelihood Deconvolution

A Journey into Model-Based Signal Processing

Explains MLD in a straightforward manner in terms of a convolutional signal generating model and ideas from optimization theory. The book focuses on the specification of a probability model for the system's measured output, determination of an appropriate likelihood function, and maximization of that function. Many practical algorithms are obtained and extensive simulations with real data are provided.

1990/227 pp., 126 illus./Hardcover/\$50.00/ISBN 0-387-97208-0

To Order: call TOLL FREE 1-800-777-4643 (in NJ, 201-348-4033) or send payment (including \$2.50 for shipping) to: Springer-Verlag New York, Inc., Attn: K. Quinn/Dept. S806, 175 Fifth Ave., New York, NY 10010. Residents of NY, NJ, MA, and CA, please add sales tax for books. Canadians please add 7% GST. Prices subject to change without notice.



Springer-Verlag

New York Berlin Heidelberg Vienna London Paris Tokyo Hong Kong Barcelona